



**ISOmantra**  
Aim • Adapt • Achieve

# Module 4

## AFFINITY DIAGRAM



## ***What is an Affinity Diagram?***

An Affinity Diagram is a tool that gathers large amounts of language data (ideas, opinions, issues) and organizes them into **groupings based on their natural relationships** (Viewgraph 1). The Affinity process is often used to group ideas generated by Brainstorming.

## ***Why should teams use the Affinity process?***

The Affinity process is a good way to get people to work on a creative level to address difficult issues. It may be used in situations that are unknown or unexplored by a team, or in circumstances that seem confusing or disorganized, such as when people with diverse experiences form a new team, or when members have *incomplete* knowledge of the area of analysis.

## ***When should we use the Affinity process?***

The Affinity process is formalized in an Affinity Diagram and is useful when you want to (Viewgraph 2)

- **Sift through large volumes of data.** For example, a process owner who is identifying customers and their needs might compile a very large list of unsorted data. In such a case, creating an Affinity Diagram might be helpful for organizing the data into groups.
- **Encourage new patterns of thinking.** An Affinity exercise is an excellent way to get a group of people to react on a "gut level" rather than mulling things over intellectually. Since Brainstorming is the first step in making an Affinity Diagram, the team considers all ideas from all members *without criticism*. This stimulus is often enough to break through traditional or entrenched thinking, enabling the team to develop a creative list of ideas.

## ***When shouldn't we use the Affinity process?***

As a rule of thumb, if less than 15 items of information have been identified, you can skip the Affinity process. Instead, you can clarify and combine the ideas and then use one of the Decision-Making Tools to identify the highest priority items.



## **What Is an Affinity Diagram?**

A tool that gathers large amounts of language data (ideas, opinions, issues) and organizes them into groupings based on their natural relationships.

## **When to Use the Affinity Process**

- Sift through large volumes of data
- Encourage new patterns of thinking



## ***How is an Affinity Diagram created?***

Affinitizing is a process performed by a group or team. The idea is to meld the perspectives, opinions, and insights of a group of people who are knowledgeable about the issues. The process of developing an Affinity Diagram seems to work best when there are no more than five or six participants.

Before we go over the steps used to create an Affinity Diagram, we need to look at some unique features of the Affinity process that are important to its success:

**Affinitize silently.** The most effective way to work is to have everyone move the displayed ideas at will, **without talking**. This is a new experience for many people. It has two positive results: It encourages unconventional thinking (which is good), while it discourages semantic battles (which are bad). It also helps prevent one person from steering the Affinity.

**Go for gut reactions.** Encourage team members not to agonize over sorting but to react quickly to what they see. Speed rather than deliberation is the order of the day, so keep the process moving.

**Handle disagreements simply.** The process provides a simple way to handle disagreements over the placement of ideas: If a team member doesn't like where an idea is grouped, he or she moves it. This creates an environment in which it is okay to disagree with people having a different viewpoint. If consensus cannot be reached, make a duplicate of the idea and place one copy in each group.

Now let's walk through the step-by-step process of creating an Affinity Diagram (Viewgraph 3). This sequence has been adapted from the *The Memory Jogger Plus+* [Ref. 1].

**Step 1 - Generate ideas.** Use the Brainstorming tool to generate a list of ideas.

The rest of the steps in the Affinity process will be easier if these ideas are written on post-its™.

**Step 2 - Display the ideas.** Post the ideas on a chartpack, a wall, or a table in a *random* manner.



## **Creating an Affinity Diagram**

Step 1 - Generate ideas

Step 2 - Display ideas

Step 3 - Sort ideas into groups

Step 4 - Create header cards

Step 5 - Draw finished diagram



**Step 3 - Sort the ideas into related groups.** The team members physically sort the cards into groupings, **without talking**, using the following process:

- ! Start by looking for two ideas that seem related in some way. Place them together in a column off to one side.
- ! Look for ideas that are related to those you've already set aside and add them to that group.
- ! Look for other ideas that are related to each other and establish new groups. This process is repeated until the team has placed all of the ideas in groups.

**NOTE:** Ideally, all of the ideas can be sorted into related groups. If there are some "loners" that don't fit any of the groups, don't force them into groupings where they don't really belong. Let them stand alone under their own headers.

**Step 4 - Create header cards for the groups.** A header is an idea that captures the **essential link among the ideas contained in a group of cards** (Viewgraph 4). This idea is written on a single card or post-it™ and must consist of a phrase or sentence that clearly conveys the meaning, even to people who are not on the team. The team develops headers for the groups by

- ! Finding already existing cards within the groups that will serve well as headers and placing them at the top of the group of related cards.
- ! Alternatively, discussing and agreeing on the wording of cards created specifically to be headers.
- ! Discovering a relationship among **two or more groups** and arranging them in columns under a **superheader**. The same rules apply for superheaders as for regular header cards.

**Step 5 - Draw the finished Affinity Diagram.**

- ! Write a problem statement at the top of the diagram.
- ! Place header and superheader cards above the groups of ideas.
- ! Review and clarify the ideas and groupings.
- ! Document the finished Affinity Diagram (Viewgraph 5).



## What Is a Header?

An idea that captures the essential link among the ideas contained in a group of cards.

- Single card or post-it™
- Phrase or sentence
- Clear meaning

## Drawing the Finished Affinity

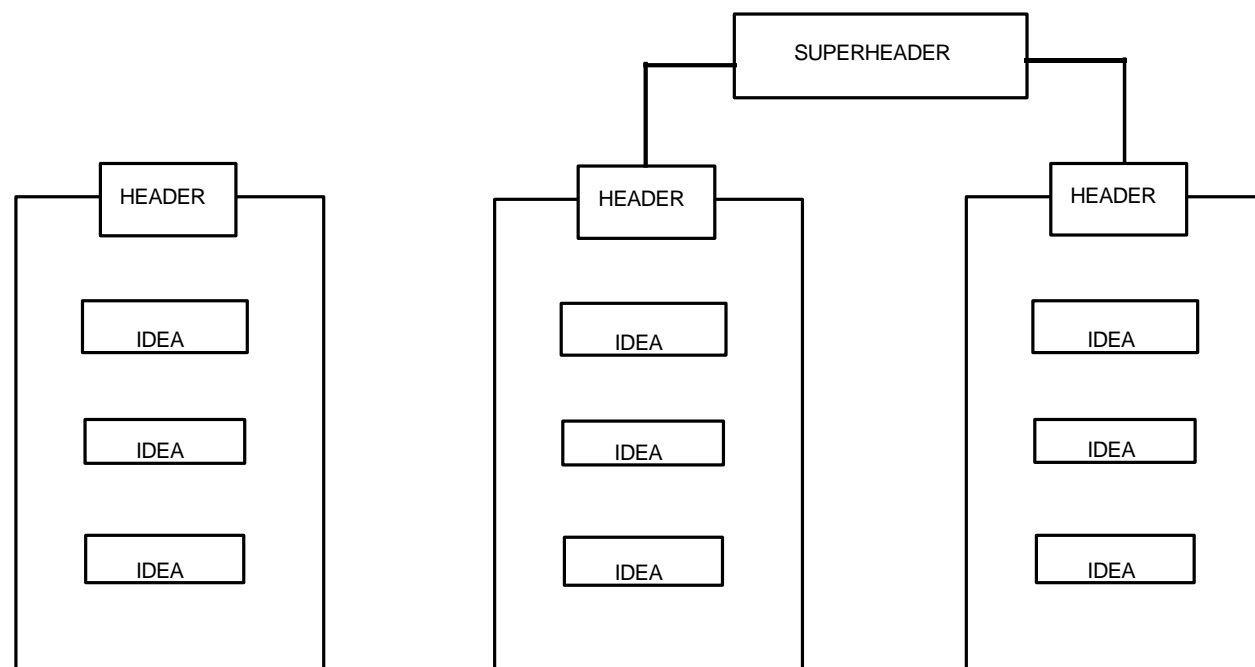



### ***How can we practice what we've learned?***

Some practical exercises will enable you to apply the skills you've just learned. These exercises are intended to be done by a team with the assistance of a facilitator or instructor. Everyone on the team should take an active part.

The first exercise takes you through the Affinity process in detail, using viewgraphs to illustrate how the random spread of cards might be grouped to arrive at a finished diagram. The diagram provided is only an example. It is different from the diagram in *Hoshin Planning* [Ref. 4, p. 4-5] from which it was adapted, and your team's groupings will probably be different from both of these. The important thing is that the finished diagram should be one that everyone on your team can live with and support.

When you have completed the detailed exercise, you may want to practice creating an Affinity Diagram for some of the other topics listed after the exercise.

**DETAILED EXERCISE:** Now let's go through the steps of the Affinity process to create a diagram using the following problem statement and the sample ideas provided in Viewgraphs 6, 7, 8, and 9.

*What are the issues in implementing continuous process improvement?*

**Step 1 - Generate ideas.** Copy each of the ideas displayed in Viewgraph 6 onto post-its™ or cards, one idea to a card. The facilitator can do this in advance, or the participants can do it at the beginning of the exercise.

**Step 2 - Display the ideas.** Place the post-its™ on a chartpack, easel, or wall, in a random manner (Viewgraph 6).

**Step 3 - Sort the ideas into related groups** (Viewgraph 7). Group the ideas by moving the cards independently. Participants should go with their gut reactions. If they disagree on the placement of a card, they are free to move it. The instructor should remind them that affinitizing is a quick process conducted in silence.



## Step 2 - Display the Ideas

### *Issues in Implementing Continuous Process Improvement*

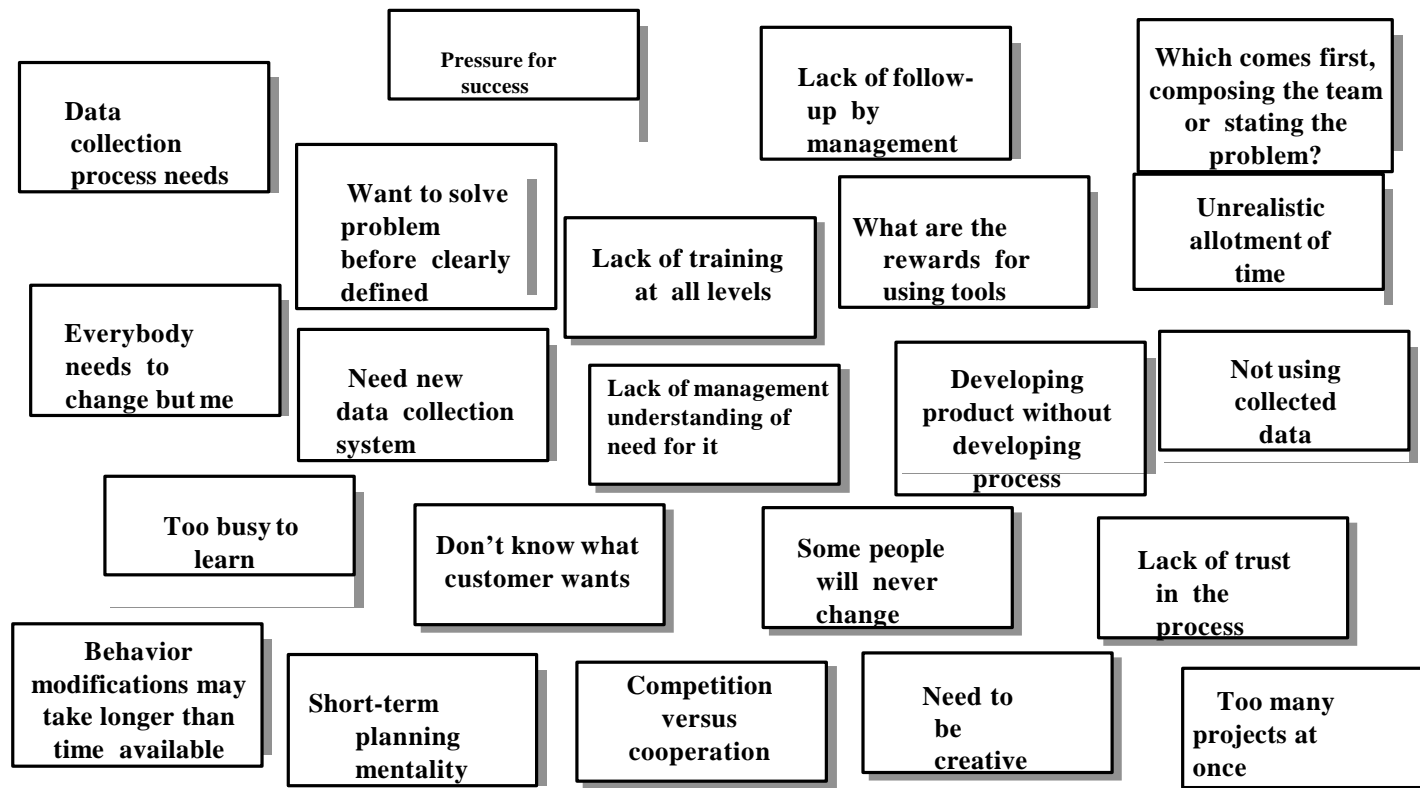

## Step 3 - Sort Ideas into Related Groups

### *Issues in Implementing Continuous Process Improvement*

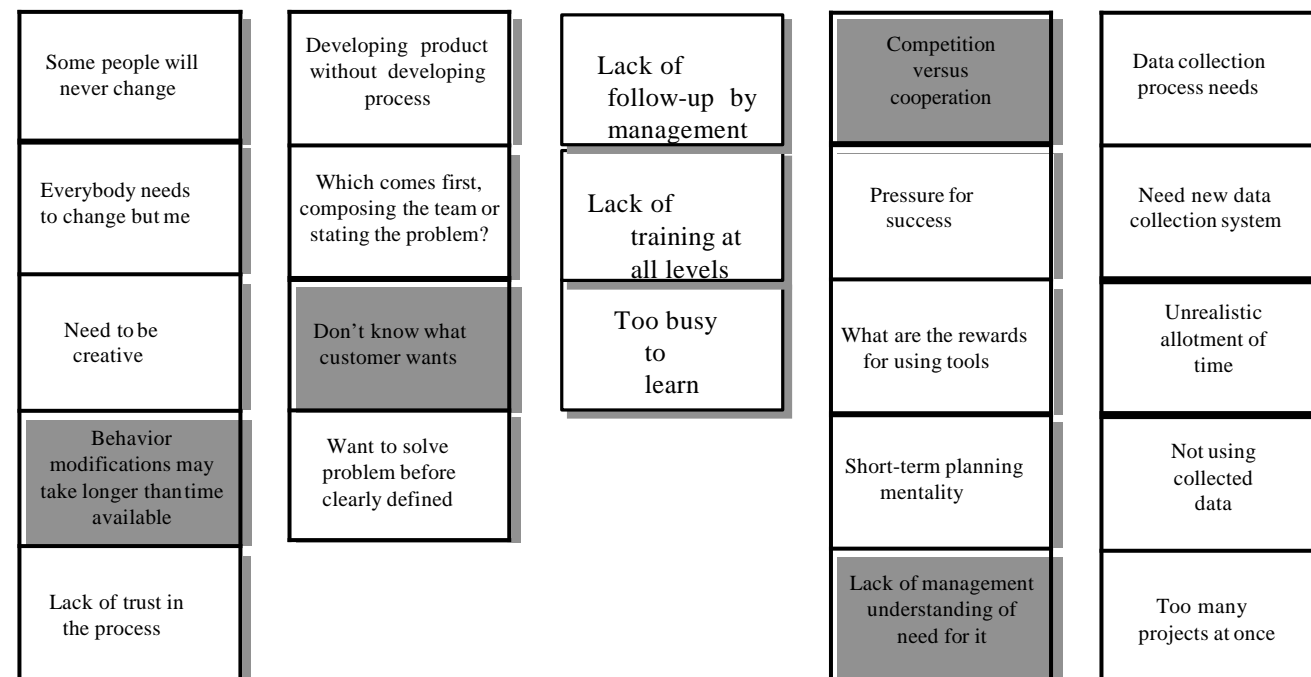



**Step 4 - Create header cards.** Make sure that each header placed at the top of a group captures the essential link among all of the ideas beneath it and consists of enough words to clearly convey the meaning. Refer to Viewgraph 8 for an example of header cards that have been developed for this exercise—or have the participants create their own.

**Step 5 - Draw the finished Affinity Diagram .** Make sure you write the problem statement on top of the diagram, place a header card above each group of ideas, allow the team to review and discuss points for clarification, and document the finished product. Refer to the completed Affinity in Viewgraph 9 for an example; but remember, it's only an example. If the participants developed their own header cards, the Affinity they create will be different.

### **OTHER EXERCISE TOPICS:**

Now try developing an Affinity Diagram for one or more of these topics:

- > How can we improve the readiness of the command?
- > What can be done about the state of readiness of the fire control systems?
- > Why is our ship dragging anchor in heavy weather?
- > What things do we need to consider in planning a perfect meeting?
- > What can be done to ensure proper disposal of recyclable material?
- > How can information flow be improved within our organization?
- > Why are the organization's vehicles getting poor gas mileage?
- > What can be done to ensure fast service at the pharmacy prescription counter?
- > What activities should we plan for the unit Christmas party?



## Step 4 - Create Header Cards

*Issues in Implementing Continuous Process Improvement*

(Header Cards)

Breaking through  
old way "Dinosaur"  
thinking

Lack of  
planning

Organizational  
Issues

Old  
management  
culture

Lack of TQL  
knowledge

## Step 5 - Draw the Finished Affinity Diagram

*Issues in Implementing Continuous Process Improvement*

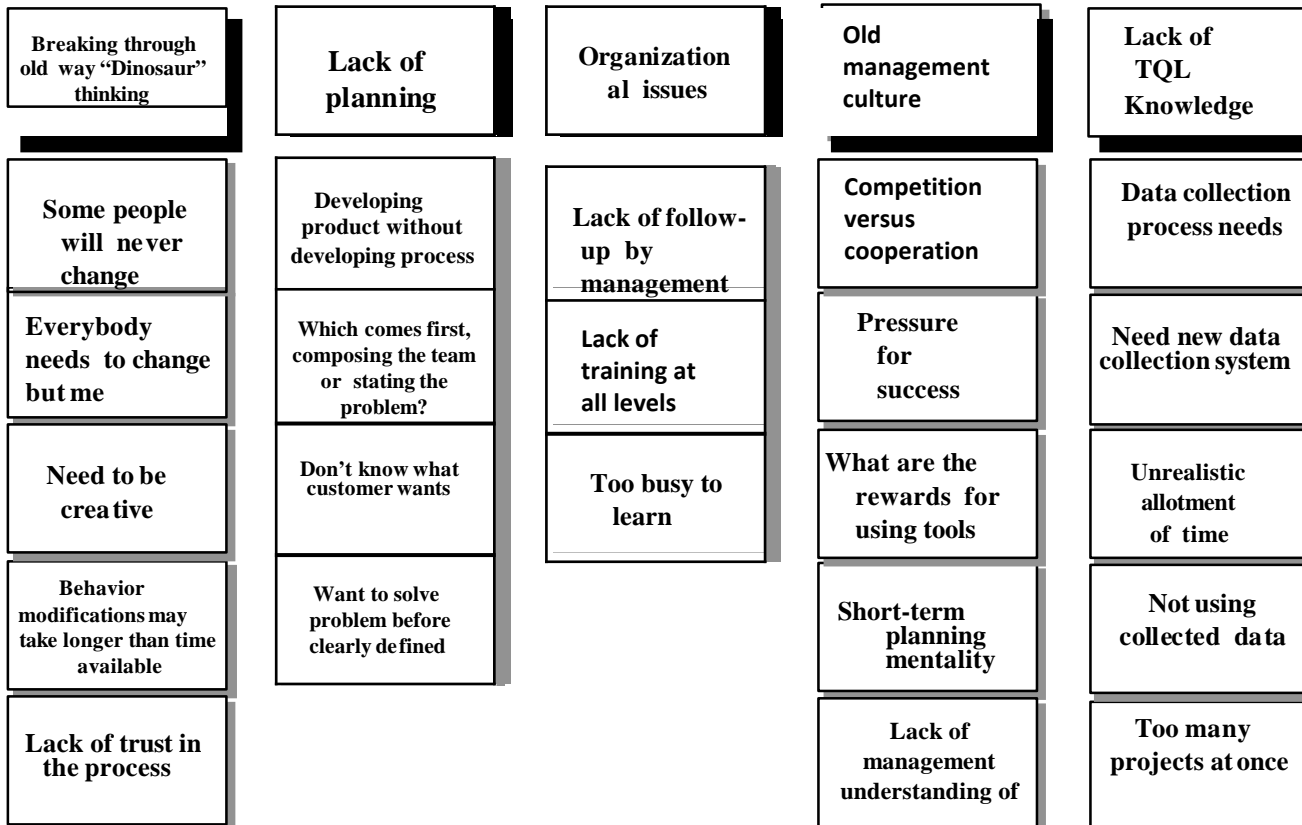



## **REFERENCES:**

- 1.Brassard, M. (1989). *The Memory Jogger Plus+*, pp. 17 - 39.  
Methuen, MA: Goal/QPC.**
  
- 1.Department of the Navy (November 1992). *Fundamentals of Total Quality Leadership (Instructor Guide)*, pp. 6-64 - 6-67. San Diego, CA: Naval Personnel Research and Development Center.**
  
- 2.Department of the Navy (June 1994). *Methods for Managing Quality (Instructor Guide)*, Module 2, Lesson 4, pp. 48 - 57.  
Washington, DC: OUSN Total Quality Leadership Office.**
  
- 1.King, R. (1989). *Hoshin Planning, The Developmental Approach*, pp. 4-2 - 4-5. Methuen, MA: Goal/QPC.**



**ISOmantra**

Aim • Adapt • Achieve

## **What Is an Affinity Diagram?**

**A tool that gathers large amounts of language data (ideas, opinions, issues) and organizes them into groupings based on their natural relationships.**



## **When to Use the Affinity Process**

- **Sift through large volumes of data**
- **Encourage new patterns of thinking**



## **Creating an Affinity Diagram**

**Step 1 - Generate ideas    Step 2 -**

**Display ideas**

**Step 3 - Sort ideas into groups**

**Step 4 - Create header cards**

**Step 5 - Draw finished diagram**



# What Is a Header?

**An idea that captures the essential link among the ideas contained in a group of cards.**

- **Single card or post-it™**
- **Phrase or sentence**
- **Clear meaning**



# Drawing the Finished Affinity



**ISOmantra**  
Aim • Adapt • Achieve

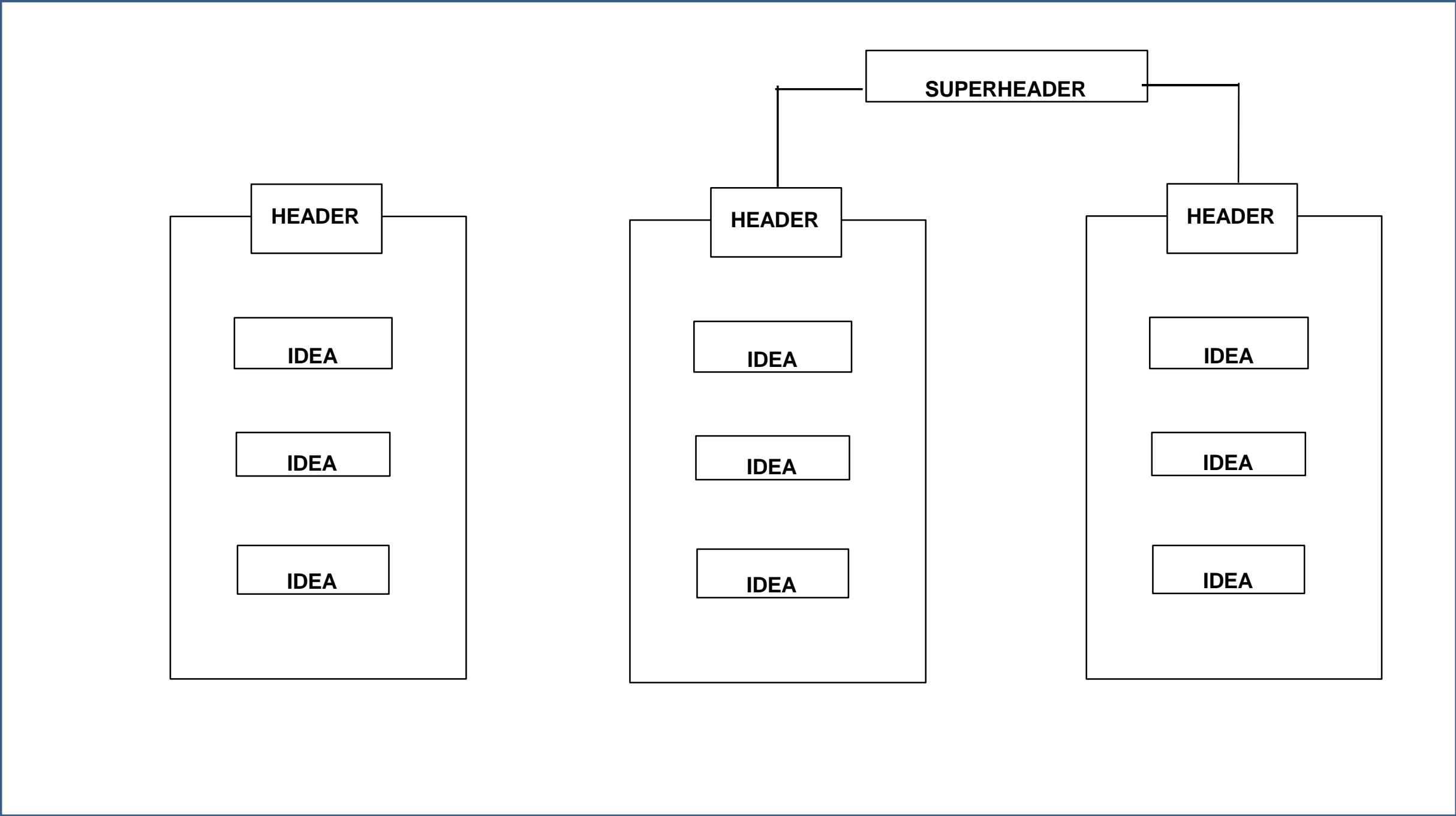

# Step 2 - Display the Ideas



## *Issues in Implementing Continuous Process Improvement*

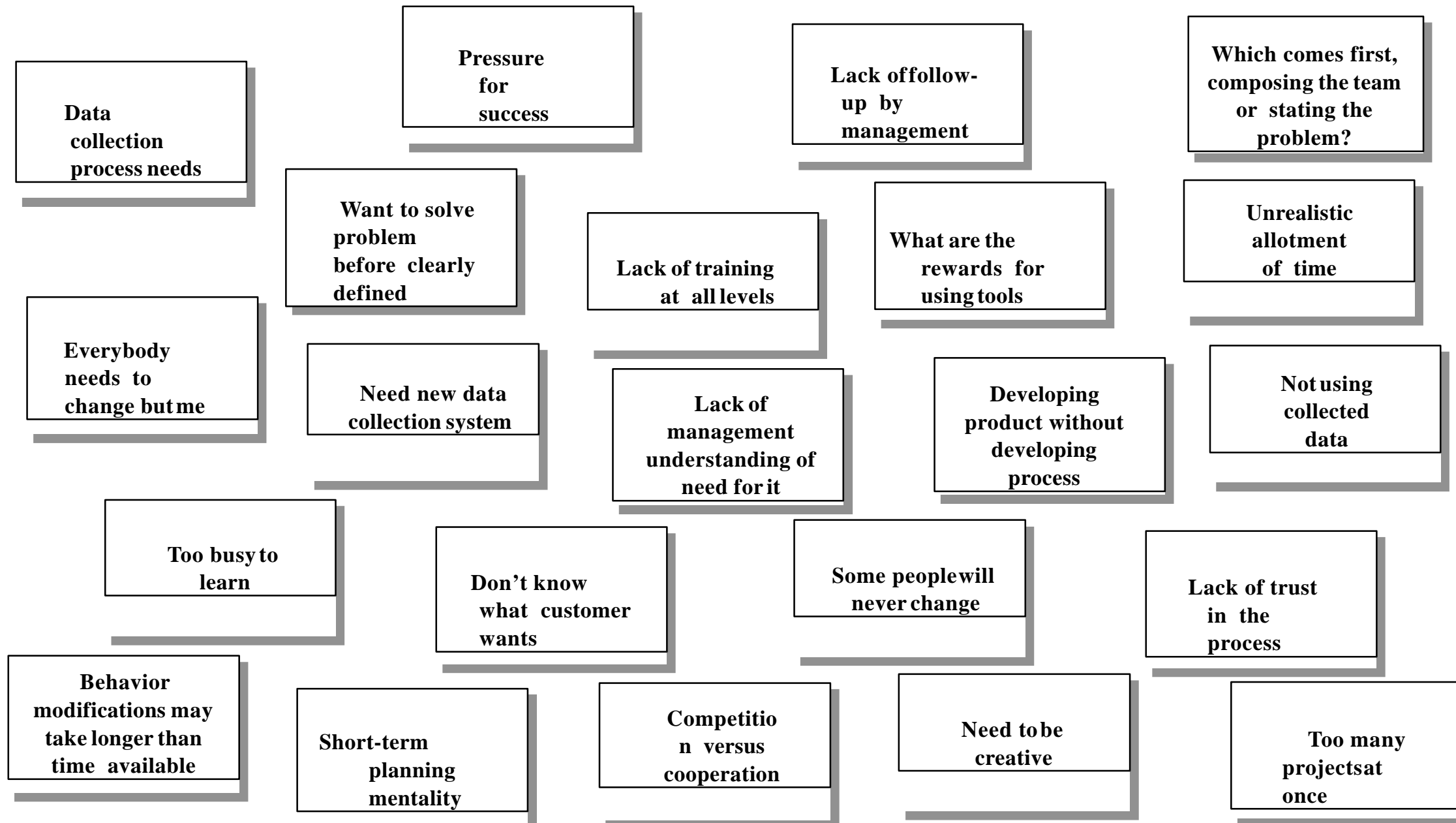

## Step 3 - Sort Ideas into Related Groups



**ISOmantra**  
Aim • Adapt • Achieve

### *Issues in Implementing Continuous Process Improvement*

Some people will never change	Developing product without developing process	Lack of follow-up by management	Competition versus cooperation	Data collection process needs
Everybody needs to change but me	Which comes first, composing the team or stating the problem?	Lack of training at all levels	Pressure for success	Need new data collection system
Need to be creative	Don't know what customer wants	Too busy to learn	What are the rewards for using tools	Unrealistic allotment of time
Behavior modifications may take longer than time available	Want to solve problem before clearly defined		Short-term planning mentality	Not using collected data
Lack of trust in the process			Lack of management understanding of need for it	Too many projects at once



## Step 4 - Create Header Cards

### *Issues in Implementing Continuous Process Improvement*

#### (Header Cards)

Breaking through  
old way  
“Dinosaur”  
thinking

Lack of  
planning

Organization  
al issues

Old  
managemen  
t culture

Lack of  
TQL  
knowledge



# Step 5 - Draw the Finished Affinity Diagram

## *Issues in Implementing Continuous Process Improvement*

